

HUDSON

ITEM _____
LENGTH _____
QTY _____

U
V
B
O
N
D
E
D

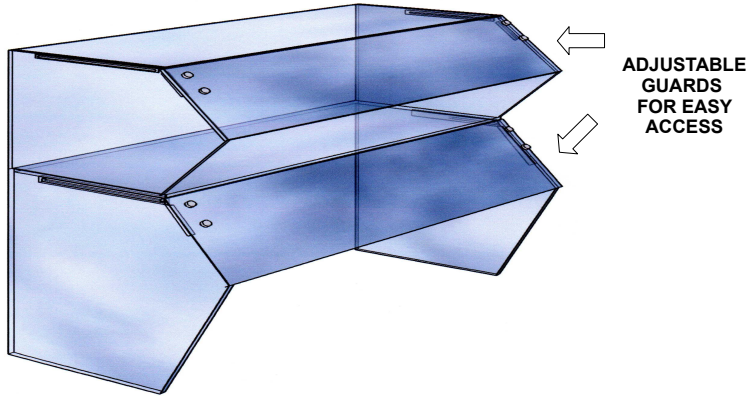

**SNEEZE GUARD
UV - BONDED
ADJUSTABLE GUARDS
FOR EASY ACCESS
MODEL SG2 - UV - A**

GENERAL DESCRIPTION

THE ALL GLASS PROTECTOR CASE IS MANUFACTURED BY HUDSON, INC CONSTRUCTED FROM CLEAR TEMPERED GLASS THAT IS IS UV BONDED CREATING A STRONG CLEAN SEAM.

FRONT GUARDS WILL SLIDE INTO TOP FOR EASY ACCESS

OPTIONS

- GLASS - 3/8" - MAXIMUM SPAN 72"
- LOW IRON CLEAR GLASS
- BRONZE GLASS
- SPECIAL WIDTH - _____
- MOUNTING - S/S CLAMPS

- GLASS - 1/2" - MAXIMUM SPAN - 96"
- GRAY GLASS
- GLASS - OTHER _____
- SPECIAL HEIGHT _____
- MOUNTING - S/S CHANNEL

LIGHT/WARMER OPTIONS

- FLOURESCENT LIGHT - SLIMLINE
- LED LIGHT - SLIMLINE
- HEAT/LIGHT COMBO SLIMLINE

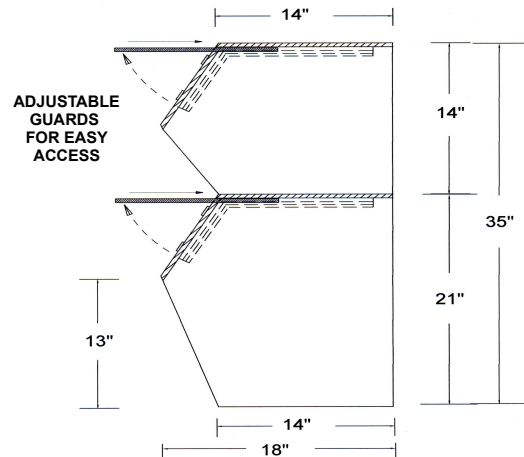
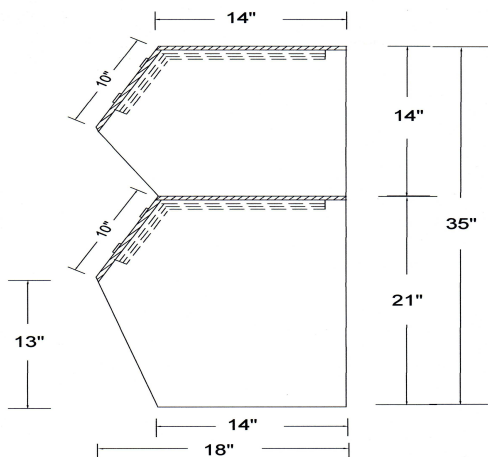

*APPROVED SHOP DRAWINGS REQUIRED
MEETS NSF 2014 STANDARDS

PATENT
PENDING

1-862-226-9775 - SALES@HUDSONSG.COM