

HUDSON

PREMIUM ANTI-VIRUS

ITEM _____
LENGTH _____
QTY _____

A
V
S
E
R
I
E
S

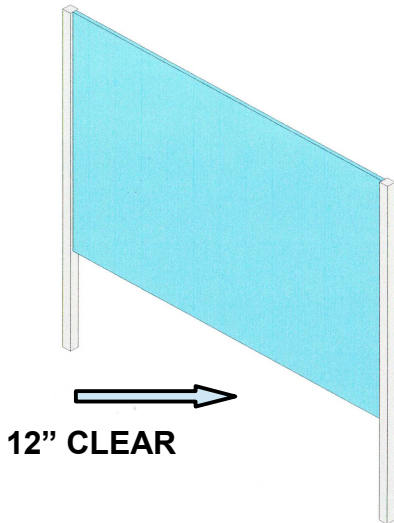

VERTICAL SHIELD
WITH PASS THRU
ACCESS - 12"
MODEL VS-A-AV

HEIGHT OF SHIELD TO BE 40"
TO MEET 76" SUGGESTED
HEIGHT REQUIREMENTS
(COUNTER HEIGHT OF 36"
PLUS 40" = 76")

GENERAL DESCRIPTION

TUBING – STAINLESS STEEL – 1" SQUARE - BRUSHED FINISH

GLASS - 3/8" TEMPERED MOUNTED TO TUBING AND CROSS MEMBERS

MOUNTING - BELOW OR ABOVE COUNTER TOP

OPTIONS

- | | |
|---|---|
| <input type="checkbox"/> PLEXIGLASS | <input type="checkbox"/> SPECIAL WIDTH _____ SPECIAL HEIGHT _____ |
| <input type="checkbox"/> TUBING – 1" ROUND _____ OTHER _____ | <input type="checkbox"/> GLASS - FROSTED |
| <input type="checkbox"/> 8" CLEAR _____ OTHER _____ | <input type="checkbox"/> LOW IRON CLEAR GLASS |
| <input type="checkbox"/> CRATED | <input type="checkbox"/> POWDER COAT - COLOR _____ |
| <input type="checkbox"/> MOUNTING – ABOVE COUNTER TOP – FLANGES | <input type="checkbox"/> MOUNTING – BELOW COUNTER TOP |

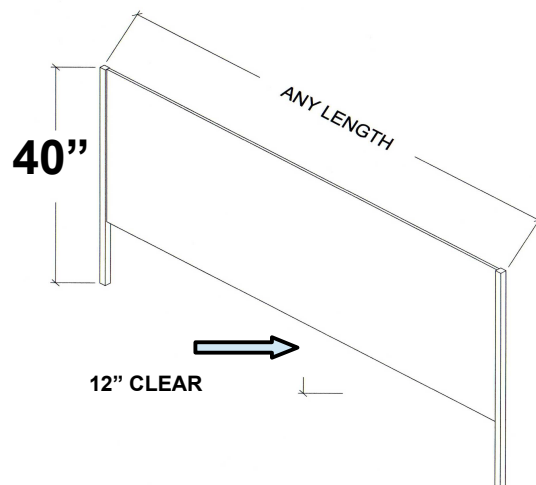
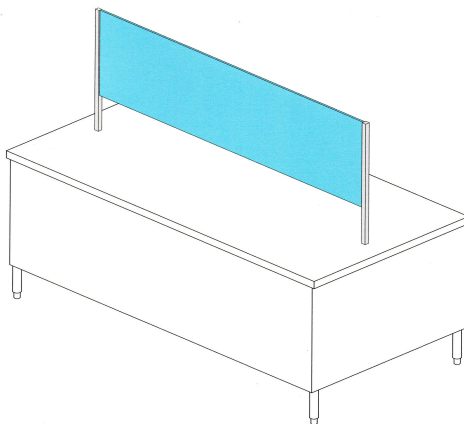

MAXIMUM SPAN BETWEEN
LEGS – 48 INCHES

*APPROVED SHOP DRAWINGS REQUIRED
MEETS NSF 2014 STANDARDS

© 2020

862-226-9775 - SALES@HUDSONSG.COM